

V. 02/21 SWITCH CIRCUIT	
WHEN CARD IS EJECTED	WHEN CARD IS INSERTED

MATERIAL AND FINISH AS BELOW			
A	Housing	HTN UL94V-0 Black	E
B	Plunger	Brass C3604,10u" Gold	F
C	Barrel	Brass C3604,10u" Gold	G
D	Spring	Stainless Steel SUS304	H

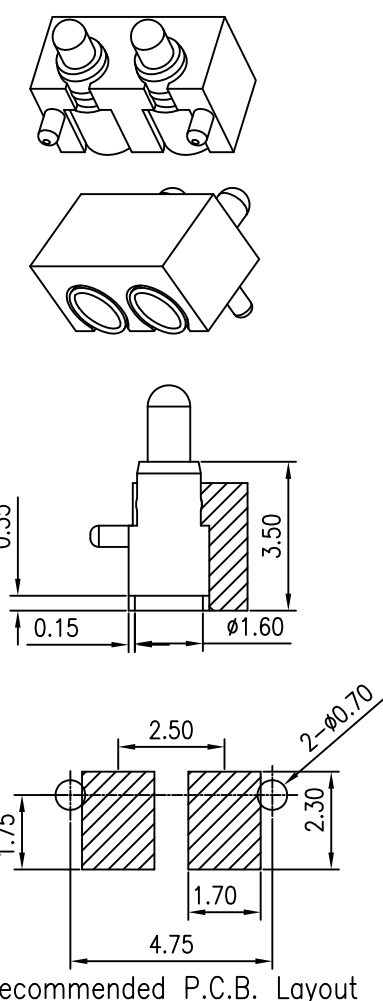
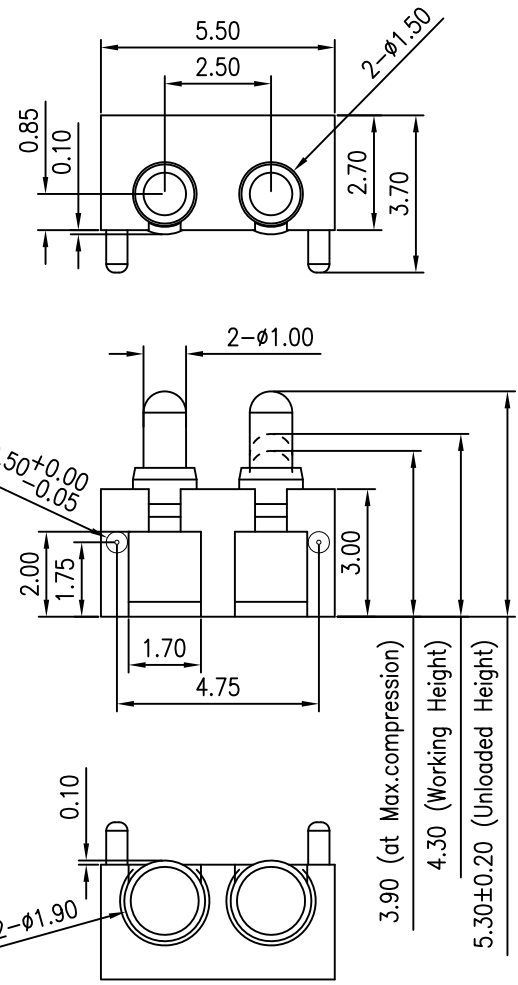

SPECIFICATION:

- ELECTRICAL**
 - Current Rating: 1A
 - Voltage Rating: 12VDC
 - Contact Resistance: 50mΩ max.
- MECHANICAL**
 - Durability: 10000 Cycle .
 - Spring Force: 120g±20% at 4.30 Working Height.
- ENVIRONMENTAL**
 - Operating temperature range: -40°C~+85°C
 - Storage temperature range: -40°C~+85°C
- SOLDER ABILITY**
 - Recommended Wave Soldering Temperature: 260°C

Alcom Singel 3 | B-2550 Kontich | Belgium | Tel. +32 (0)3 458 30 33 | info@alcom.be | www.alcom.be
 Rivium 1e straat 52 | 2909 LE Capelle aan den IJssel | The Netherlands | Tel. +31 (0)10 288 25 00 | info@alcom.nl | www.alcom.nl

P1	P2	P3	P4	P5	P6	P7	P8	P9	P10	P11	P12
PIN ASSIGNMENT											
303B-351819-25-000 Pogo Pin Two Pin, Pitch:2.5 Height:5.3, Contact Plating: 10u" Gold											
PRODUCT NO.						DESCRIPTION					

UNLESS OTHERWISE SPECIFIED TOLERANCE		
ANGLES	ANG.	±5°
LINEAR	0.	±0.3
	0.00	±0.25
SCALE	AS SHOWN	UNIT: mm
DRAWN	Willis	2014/04/22
CHECKED	Angel	2014/04/22
APPROVED	Ken	2014/04/22

www.attend.com.tw

DRAWN NAME: Pogo Pin Two Pin

PRODUCT NO. 303B-351819-25-000

FILE NAME 303B-351819-25-000_B_2

REV.	DESCRIPTION	DATE	REV.	DESCRIPTION	DATE
3	Revise:				
2	Revise:				
1	Revise:				

G
F
E
D
C
B
A

G
F
E
D
C
B
A