

ION/CME® N-Series

Digital Drives

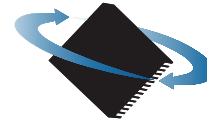

**PERFORMANCE
MOTION DEVICES**

MOTION CONTROL AT ITS CORE

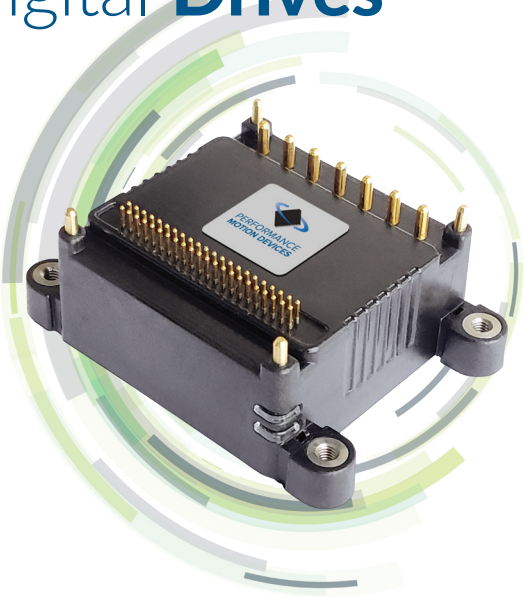

ION/CME N-Series Digital Drives are compact, PCB-mountable versions of PMD's ION Digital Drive family that provide high performance motion control, network connectivity and amplification. Three power output levels are available - 75, 350, and 1,000 Watts. All IONs can drive DC Brush, Brushless DC and step motors, and are ideal for medical, mobile, scientific, semiconductor, and other automation applications.

Powerful Features

N-Series IONs provide high power density in a patented ultra-rugged form factor. They perform profile generation, servo compensation, stall detection, field oriented control, digital torque control and many other motion control functions. Additional features include Ethernet, CAN, serial, and SPI (Serial Peripheral Interface) communications.

Time to Market Breakthrough

N-Series IONs represent a new paradigm for building application specific controllers. Instead of designing boards from the ground up with dozens or hundreds of IC components, plug and play N-Series ION modules allow fully functional custom boards to be designed and produced in weeks instead of months or even years.

Easy to Use and Program

Working with PMD's powerful Pro-Motion® Windows-based GUI makes it easy to graph and analyze motion control performance, while the onboard C-Motion® Engine allows users to directly run their application on the N-Series ION. Most importantly, at the core of every ION/CME N-Series Digital Drive is a PMD Magellan Motion Control IC, guaranteeing software compatibility and insuring performance and reliability second to none.

FEATURES

- DC Brush, Brushless DC and step motor versions
- Ethernet, CAN FD, serial or SPI host communications
- Fully user programmable
- S-curve, trapezoidal, velocity contouring, electronic gearing profiles
- 75 W, 350 W, or 1,000 W power rating
- Up to 20 A continuous output
- 12-56 V single power source
- 20, 40, 80 and 120 kHz PWM frequency
- 20 kHz servo loop rate
- Auxiliary encoder input supports cam, gearing and dual loop applications
- Dimensions: 1.48" x 1.48" x 0.66" (38mm x 38mm x 17mm)
- Patented ultra-rugged PCB-mountable package
- Autotuning for easy setup
- Supports quadrature, sin/cos, BiSS-C encoders
- FOC (Field Oriented Control)
- Sinusoidal commutation
- Stall detection
- Programmable acceleration and deceleration
- Advanced PID filter with velocity and acceleration feedforward
- Programmable dual biquad filters
- +/- 10V high resolution 16-bit ADC input
- 8 general purpose bi-directional I/O's
- Execution of user code at up to 418 MIPS
- 256 KB of programmable user code space
- 256 KB user application RAM space

CONFIGURATION

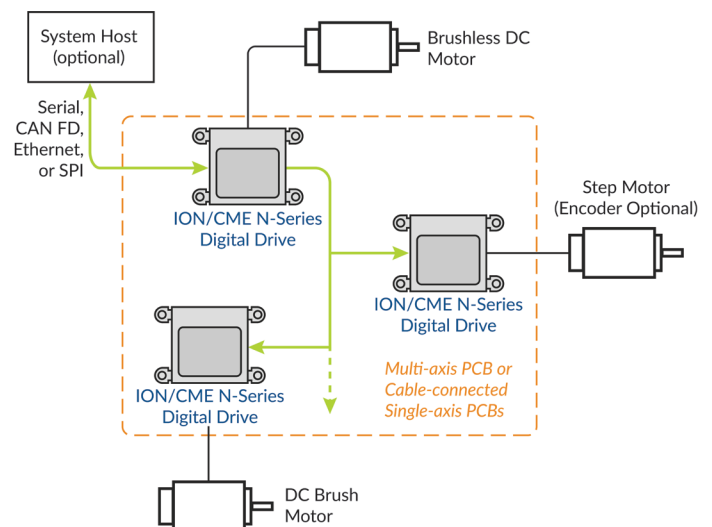

Technical Overview

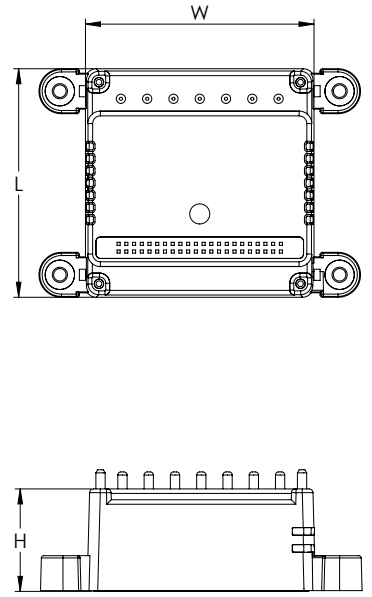
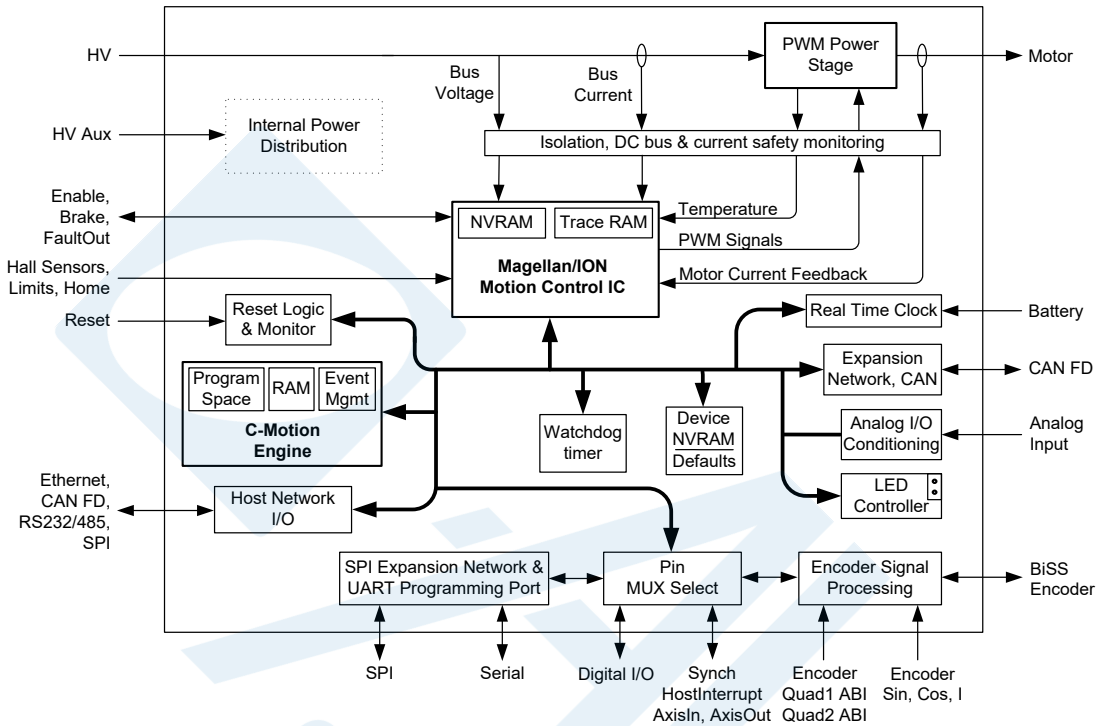

SPECIFICATIONS

Parameter	Value
Supported Motor Types	Brushless DC, step motor, DC Brush
Power levels available	Low (75 W), Medium (350 W), High (1,000+ W)
Voltage input	12-56V
Profile modes	S-curve point-to-point, trapezoidal point-to-point, velocity contouring, electronic gear, user defined
Position loop	PID with velocity & accel feedforward and dual biquads
Current loop	PI with FOC (Field Oriented Control)
Position loop rate	Up to 19.53 kHz (user programmable)
Current loop rate	19.53 kHz
PWM frequency	20 kHz, 40 kHz, 80 kHz, 120 kHz
Multi-axis synchronization	<1 uSec using Synch signal
Host communication	CAN FD, Serial (RS232, RS485, RS422), Ethernet 100 Base-T, SPI (Serial Peripheral Interface)
Additional communication	Expansion CAN, Expansion SPI
Encoder formats supported	Quadrature, sin/cos, BiSS-C, pulse & direction
Quad encoder rate	40 MCounts/sec
User program NVRAM	256 KB
Multi-tasking	Yes, up to 16 tasks
C-Motion Engine speed	428 MIPS
General purpose I/O	8 bi-directional digital I/Os, 1 analog input (16 bit A/D)
Drive safety features	Over current, over temperature, over/under voltage, i2T current foldback, brake signal, shunt control

MECHANICAL DIMENSIONS

Model	Length (L)	Width (W)	Height (H)
All Units	1.479 (in) 37.6 (mm)	1.479 (in) 37.6 (mm)	0.663 (in) 16.8 (mm)

RATINGS

Model	Low Power Units	Medium Power Units	High Power Units
Brushless DC current, continuous	1.5 Arms	5.5 Arms	14.8 Arms
Brushless DC current, peak	3.8 A	14.0 A	33.0 A
Brushless DC power, continuous	103 W	379 W	1,018 W
Step motor current, continuous	1.5 Arms	5.0 Arms	13.4 Arms
Step motor current, peak	3.8 A	14.0 A	33.0 A
Step motor power, continuous	119 W	396 W	1,064 W
DC Brush current, continuous	1.5 A	7.1 A	19.0 A
DC Brush current, peak	3.8 A	14.0 A	33.0 A
DC Brush power, continuous	84 W	396 W	1,064 W

SAFETY AND COMPLIANCE

Specifications	Standard
CE	LVD: EN60204-1, EMC-D: EN61000-6-1, EN61000-6-3, EN55011
Electrical safety	Designed to UL508C, UL840 and EN60204-1
Flammability	UL94-HB
Enclosure	IP20

Development Tools

1 EASY START-UP Developer Kit

INCLUDES

- N-Series ION Developer Kits available
- Pro-Motion software
- Software Development Kit (SDK) with C-Motion
- Complete manual set
- Complete cable and prototyping connector set

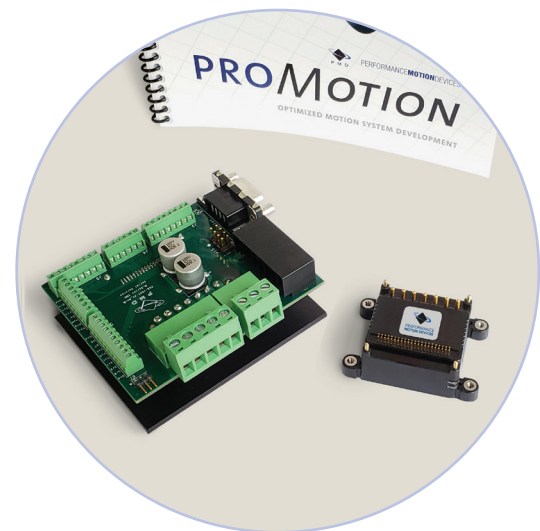

2 TUNE & OPTIMIZE Pro-Motion® GUI

Pro-Motion is a sophisticated, easy-to-use Windows-based exerciser program for use with PMD motion control ICs, modules, and boards.

FEATURES

- Motion oscilloscope graphically displays processor parameters in real-time
- Autotuning
- Ability to save and load settings
- Axis wizard
- Distance and time units conversion
- Motor-specific parameter setup
- Axis shuttle performs programmable motion between two positions
- Communications monitor echoes all commands sent by Pro-Motion to the board
- Advanced Bode analysis for frequency machine response

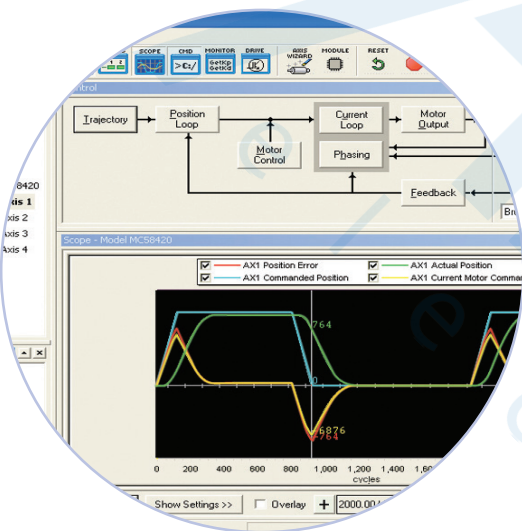

3 BUILD THE APP C-Motion®

C-Motion is a complete, easy-to-use, motion programming language that includes a source library containing all the code required for communicating with PMD motion ICs, boards, and drives.

FEATURES:

- Extensive library of commands for virtually all motion design needs
- Develop embeddable C/C++ applications
- Complete, functional examples
- Supports serial, CAN, Ethernet, SPI, and PC104 communications

```
// code for executing a profile and tracing
// the trace buffer wrap mode to a one time trace
PMDTraceMode(hAxis1, PMDTraceOneTime);

// set the processor variables that we want to capture
PMDTraceVariable(hAxis1, PMDTraceVariable1, PMDAxis1);
PMDTraceVariable(hAxis1, PMDTraceVariable2, PMDAxis1);
PMDTraceVariable(hAxis1, PMDTraceVariable3, PMDAxis1);

// set the trace to begin when we issue the next update command
PMDTraceStart(hAxis1, PMDTraceConditionNextUpdate);

// set the trace to stop when the MotionComplete event occurs
PMDTraceStop(hAxis1, PMDTraceConditionEventStatus,
PMDEventMotionCompleteBit, PMDTraceStateHigh);
PMDTraceProfileMode(hAxis1, PMDTrapezoidalProfile);

// set the profile parameters
PMDProfilePosition(hAxis1, 200000);
PMDProfileVelocity(hAxis1, 0x200000);
PMDProfileAcceleration(hAxis1, 0x1000);
PMDProfileDeceleration(hAxis1, 0x1000);

// motion
PMDMotion(hAxis1);
```

PMD PRODUCT FAMILY OVERVIEW

	# Axes	Motor Types	Format	Voltage	Communication	Features
JUNO® VELOCITY & TORQUE CONTROL ICs 	1	<ul style="list-style-type: none"> Brushless DC DC Brush Step Motor 	<ul style="list-style-type: none"> 64-pin TQFP 56-pin VQFN 	3.3 V	<ul style="list-style-type: none"> RS232/485 CANbus SPI 	<ul style="list-style-type: none"> Velocity control Current control Field oriented control
MAGELLAN® MOTION CONTROL ICs 	1,2,3,4	<ul style="list-style-type: none"> Brushless DC DC Brush Step Motor 	<ul style="list-style-type: none"> 144-pin TQFP 100-pin TQF 	3.3 V	<ul style="list-style-type: none"> RS232/485 CANbus SPI Parallel 	<ul style="list-style-type: none"> Position control Torque/current control Field-oriented control Profile generation
ATLAS® DIGITAL AMPLIFIERS 	1	<ul style="list-style-type: none"> Brushless DC DC Brush Step Motor 	<ul style="list-style-type: none"> 20-pin solderable module 	12-56 V	<ul style="list-style-type: none"> SPI Pulse and direction 	<ul style="list-style-type: none"> Torque/current control Field-oriented control MOSFET amplifier
ION®/CME N-SERIES DIGITAL DRIVES 	1	<ul style="list-style-type: none"> Brushless DC DC Brush Step Motor 	<ul style="list-style-type: none"> Fully enclosed PCB-mounted module 	12-56 V	<ul style="list-style-type: none"> Ethernet RS232/485 CAN FD SPI 	<ul style="list-style-type: none"> Position control Torque/current control Field-oriented control Profile generation MOSFET amplifier Downloadable user code
ION® 500 & 3000 DIGITAL DRIVES 	1	<ul style="list-style-type: none"> Brushless DC DC Brush Step Motor 	<ul style="list-style-type: none"> Fully enclosed cable-connected module 	12-56 V 20-195 V	<ul style="list-style-type: none"> Ethernet RS232/485 CANbus 	<ul style="list-style-type: none"> Position control Torque/current control Field-oriented control Profile generation MOSFET amplifier Downloadable user code
PRODIGY® MOTION BOARDS 	1,2,3,4	<ul style="list-style-type: none"> Brushless DC DC Brush Step Motor 	<ul style="list-style-type: none"> Machine Controller PC/104 Standalone 	<ul style="list-style-type: none"> 5 V: PC/104 and Standalone 12-56 V: Machine Controller 	<ul style="list-style-type: none"> Ethernet RS232/485 CANbus PC/104 bus 	<ul style="list-style-type: none"> Position control Torque/current control Field-oriented control Profile generation Downloadable user code

C-Motion® is the common motion language for all Performance Motion Devices products.

FOR ORDERING ION DIGITAL DRIVES

DD131S0056/15

Use Type: D Standard K Development Kit	ION Body Style: 1 ION 500 and 3000 3 ION 500 CME 4 N-Series ION	Motor Type: 1 DC Brush 3 BLDC 4 Step 8 Multimotor	# of Axis: 1	Communication: S Serial D Ethernet+Serial C CAN	Power Selection: 0056/02 N-Series ION - Low 0056/06 N-Series ION - Medium 0056/15 ION 500 0056/18 N-Series ION - High 0195/30 ION 3000
---	---	--	------------------------	---	--

To place an order email purchaseorders@pmdcorp.com. For questions email support@pmdcorp.com

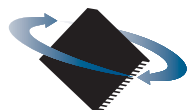

PERFORMANCE MOTION DEVICES
MOTION CONTROL AT ITS CORE

About Performance Motion Devices

Performance Motion Devices (PMD) is a worldwide leader in motion control ICs, boards and modules. Dedicated to providing cost-effective, high performance motion systems to OEM customers, PMD utilizes extensive in-house expertise to minimize time-to-market and maximize customer satisfaction.

1 Technology Park Dr, Westford, MA 01886
 Tel: 978.266.1210 Fax: 978.266.1211
 e-mail: info@pmdcorp.com
www.pmdcorp.com

ATLAS, ION, Juno, Magellan, Navigator, Pilot, Prodigy, C-Motion and Pro-Motion are trademarks of Performance Motion Devices, Inc. All other trade names, brand names and company names are the property of their respective owners. 2021 Performance Motion Devices, Inc.

Rev. 1/2021



Singel 3 | B-2550 Kontich | Belgium | Tel. +32 (0)3 458 30 33 | info@alcom.be | www.alcom.be

Rivium 1e straat 52 | 2909 LE Capelle aan den IJssel | The Netherlands | Tel. +31 (0)10 288 25 00 | info@alcom.nl | www.alcom.nl